



B94 MAGNETIC (70mph/112kph) LED BEACON

Amber. Flash rate 70 groups of 5 flashes per minute. Operating temperature -30° to 50°.

B94.70.LMV
10V-49V DC

For operating and fitting details see page 5.

Spare Parts

- 10438.10 Amber Lens.
- 13606.51 Led Module.
- 14218.00 Single Pole Plug.
- 10085 Internal Fresnel Lens.

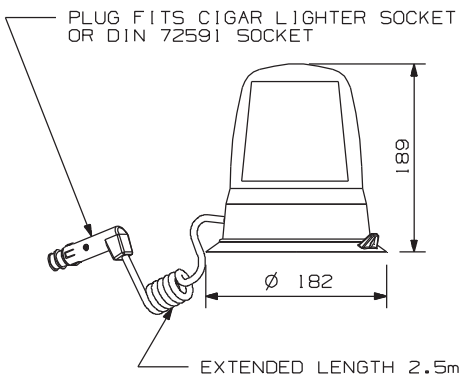

B25 PLUG-IN FLEXI BASE ROTATING HALOGEN BEACON

Amber. Polycarbonate Lens. Flash rate 160 flashes per minute. Operating temperature -30° to 50°.

B25.12V/.24V

Use with 13109 series fixing socket (not supplied with beacon) see page 29.

Specify voltage when ordering. Less bulb (.LB) versions available .12LB or .24LB

Spare Parts

- 10541.00 Amber Lens.
- 27031 Bulb Retaining Clip.
- H448 12V (55W) Halogen Bulb.
- H466 24V (70W) Halogen Bulb.

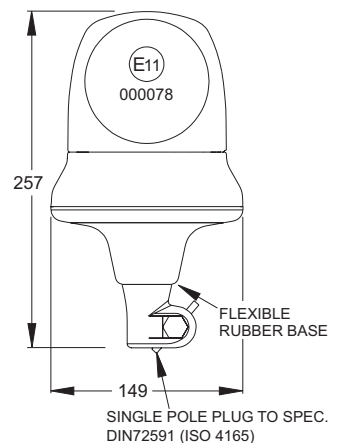

All Magnetic Beacons require a **mating single pole socket**, see **Electrical Equipment** Section **page 86.**

B24, 324, 394, B14, 284, 394 series beacons include a **vehicle cigar lighter adaptor.**